

## INTERNATIONAL JOURNAL OF ENGINEERING SCIENCES & RESEARCH TECHNOLOGY

### Numerical Analysis and Optimization of Engine Cylinder Fins of Varying Geometry and Material

Dr. S.v. Saravanan<sup>\*1</sup>, L.Suresh<sup>2</sup>, M.Murugasan<sup>3</sup>, V.Mahendran<sup>4</sup>, M.Vairavel<sup>5</sup>

<sup>\*1,2</sup> Professor-Mechanical Engineering, Christ The King Engineering College Karamadai, India

<sup>3</sup> Assistant Professor, Mechanical Engineering, Christ The King Engineering College, India

<sup>4</sup> PG scholar -Mechanical Engineering, Christ the King Engineering College Karamadai India

<sup>5</sup> R&D –fit Look design Solutions, India

#### Abstract

The main aim of the project is to analyze the thermal properties by varying geometry, material and thickness of cylinder fins. Parametric models of cylinder with fins have been developed to predict the transient thermal behavior. The models are created by varying the geometry, rectangular, circular and curved shaped fins and also by varying thickness of the fins. The 3D modeling software used is Pro/Engineer. The analysis is done using ANSYS. Presently Material used for manufacturing cylinder fin body is Aluminum Alloy 204 which has thermal conductivity of 110-150W/mk. We are analyzing the cylinder fins using this material and also using Aluminum alloy 6061 and Magnesium alloy which have higher thermal conductivities.

**Keywords:** Engine Cylinder Fins , Material , Fea Anlysis

#### Introduction

The internal combustion engine is an engine in which the combustion of a fuel (normally a fossil fuel) occurs with an oxidizer (usually air) in a combustion chamber. In an internal combustion engine, the expansion of the high-temperature and -pressure gases produced by combustion applies direct force to some component of the engine, such as pistons, turbine blades, or a nozzle. This force moves the component over a distance, generating useful mechanical energy

#### Necessity Of Cooling System In Ic Engines



Figure 1.1 IC engine cooling system

All the heat produced by the combustion of fuel in the engine cylinders is not converted into useful power at the crankshaft. A typical distribution for the fuel energy is given below:

Useful work at the crank shaft	= 25	per cent	Loss to the cylinders walls	= 30 per cent
Loss in exhaust gases	= 35	per cent	Loss in friction	= 10 per cent

#### Steps Involved In The Project

1. Modeling
2. Theoretical Calculation
3. Transient Thermal Analysis

## Literature Survey

**Cooling System Of Ic Engines :** Heat engines generate mechanical power by extracting energy from heat flows, much as a water wheel extracts mechanical power from a flow of mass falling through a distance. Engines are inefficient, so more heat energy enters the engine than comes out as mechanical power; the difference is waste heat which must be removed. Internal combustion engines remove waste heat through cool intake air, hot exhaust gases, and explicit engine cooling

**Basic Principles :** Most internal combustion engines are fluid cooled using either air (a gaseous fluid) or a liquid coolant run through a heat exchanger (radiator) cooled by air. Marine engines and some stationary engines have ready access to a large volume of water at a suitable temperature. The water may be used directly to cool the engine, but often has sediment, which can clog coolant passages, or chemicals, such as salt, that can chemically damage the engine. Thus, engine coolant may be run through a heat exchanger that is cooled by the body of water

**Thermal Analysis :** Thermal analysis is a branch of materials science where the properties of materials are studied as they change with temperature. Several methods are commonly used - these are distinguished from one another by the property which is measured. Thermal Analysis is also often used as a term for the study of Heat transfer through structures. Many of the basic engineering data for modelling such systems comes from measurements of heat capacity and Thermal conductivity.

## Equations

Length of fin (L)=130mm=0.13m

Width of fin (b)=130mm=0.13m

Thickness  $y=2.5\text{mm}$

$2y=5\text{mm}=0.005\text{m}$

Perimeter of fin (P) = 0.1273m

K=conductivity of fin material =120W/Mk

h=heat transfer coefficient =25W/m<sup>2</sup>K.

Cross sectional area of fin  $A_c=b \times y$

Where T=temperature of cylinder head=458K  $T_a$ =atmospheric temperature=313K

x=distance measured from base of fin=65mm=0.065m.

## Maximum heat transferable by fin when if entire fin at base temperature

$$Q_{\max}=h (Pl) (t_0-t_a) = h (Pl) \Theta_0$$

$$\eta = (Q_{\text{fin}}/Q_{\max})$$

## Effectiveness of fin

$$\epsilon = \frac{\text{heat lost with fin}}{\text{heat lost without fin}}$$

## Where

L = Length of fin (m) W = Width of fin (m)

$\delta$  = Thickness of fin (m)

P = Perimeter of fin (m)

$A_c$  = Cross sectional area of fin (m<sup>2</sup>)

K = Conductivity of fin material (W/mK)

h = Heat transfer coefficient (W/m<sup>2</sup>K)

$\theta$  = Temperature (K)

$\theta_0$  = Temperature (K)

T = Temperature of cylinder head (K)

$T_a$  = Atmospheric temperature (K)

x = Distance measured from base of fin (m)

Q = Heat lost by fin (W/m)  $\epsilon$  = Effectiveness of fin

A = Contact Area (m<sup>2</sup>)

$T_i$  = Inside Temperature (K)

$T_o$  = Outside Temperature (K) U = Film Coefficient (W/m<sup>2</sup>K) q = Heat Flow (W)

h = Heat Flux (W/m<sup>2</sup>)

$T_g = T_h$

**Aluminum Alloy 6061 – 3 Mm Thickness (Curved & Circular Shapes)**

**Material Properties**

Thermal Conductivity – 180 w/mk

Specific Heat – 0.896 J/g °C

Density – 2.7g/cc

**Loads**

Temperature -558 K

Film Coefficient – 25 w/m<sup>2</sup> K Bulk

Temperature – 313 K

**NODAL TEMPERATURE:**

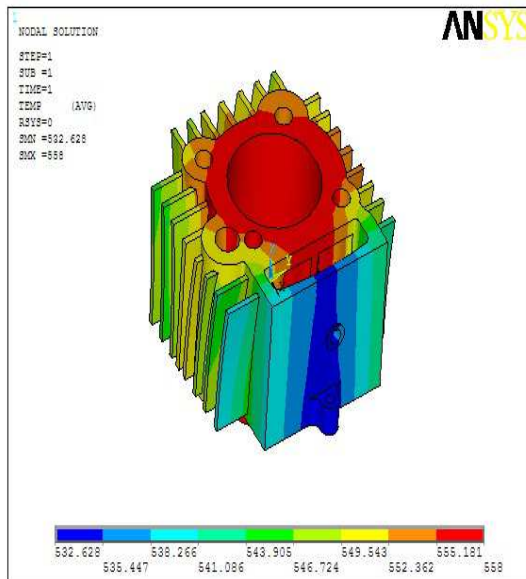

**THERMAL GRADIENT SUM :**

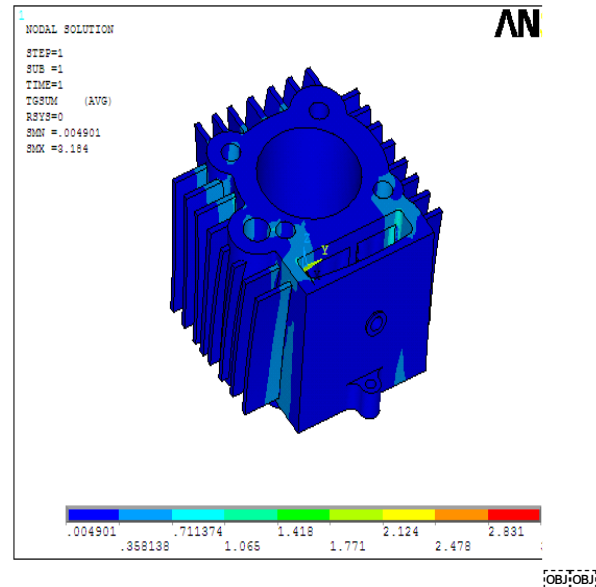

**NODAL TEMPERATURE:**

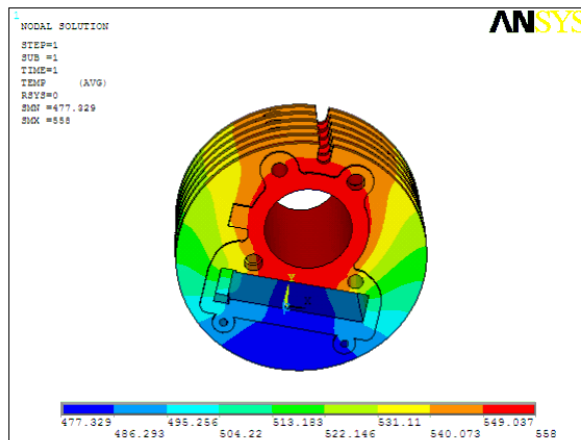

**THERMAL GRADIENT SUM :**

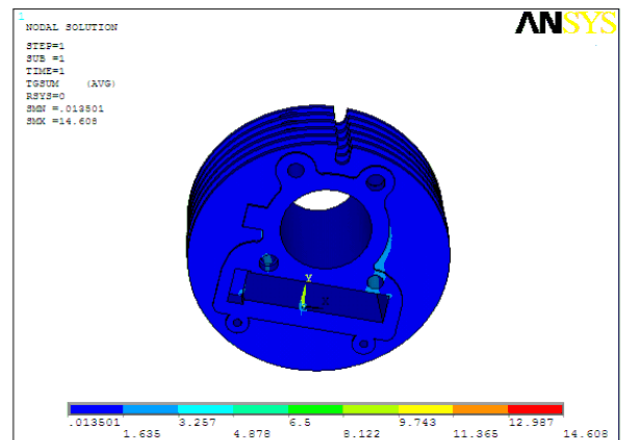

**Analysis Results Table**

**5.1 Rectangular Fins**

	3 mm Thickness			2.5mm Thickness		
	Aluminum Alloy 204	Aluminum Alloy 6061	Magnesium	Aluminum Alloy 204	Aluminum Alloy 6061	Magnesium
Nodal Temperature (K)	558	558	558	558	558	558

Thermal Gradient (K/mm)	6.997	4.85	5.434	5.319	3.684	4.128
Thermal Flux (w/mm <sup>2</sup> )	0.839666	0.873051	0.863962	0.638316	0.66133	0.656373

### 5.2 Circular Fins

	3 mm Thickness			2.5mm Thickness		
	Aluminum Alloy 204	Aluminum Alloy 6061	Magnesium	Aluminum Alloy 204	Aluminum Alloy 6061	Magnesium
Nodal Temperature (K)	558	558	558	558	558	558
Thermal Gradient (K/mm)	14.608	10.612	11.736	16.117	11.744	12.165
Thermal Flux (w/mm <sup>2</sup> )	1.753	1.91	1.866	1.934	2.114	1.934

### 5.3 Curved Fins

	3 mm Thickness			2.5mm Thickness		
	Aluminum Alloy 204	Aluminum Alloy 6061	Magnesium	Aluminum Alloy 204	Aluminum Alloy 6061	Magnesium
Nodal Temperature (K)	558	558	558	558	558	558
Thermal Gradient (K/mm)	4.632	3.184	1.809	2.482	1.609	3.575
Thermal Flux (w/mm <sup>2</sup> )	0.555799	0.573126	0.287604	0.297862	0.289587	0.568437

### Mass Of Cylinder Fins

#### 3 Mm THICK FINS

	Al 204	Al 6061	Mg
Rectangular	1.0100279 Kg	9.7395552 e <sup>-1</sup> Kg	8.9459618 e <sup>-1</sup> Kg
Circular section	1.1846582 Kg	1.1423490 Kg	1.0492687 Kg
Curved fins	8.9376056 e <sup>-1</sup> Kg	8.6184054 e <sup>-1</sup> Kg	7.9161649 e <sup>-1</sup> Kg

#### 2.5 Mmthick FINS

	Al 204	Al 6061	Mg
Rectangular	9.7228382 e <sup>-1</sup> Kg	9.3755940 e <sup>-1</sup> Kg	8.6116567 e <sup>-1</sup> Kg
Circular section	1.1204059 Kg	1.0803914 Kg	9.9235955 e <sup>-1</sup> Kg
Curved fins	9.2521898 e <sup>-1</sup> Kg	8.927545 e <sup>-1</sup> Kg	8.1947967 e <sup>-1</sup> Kg

### Theoretical Results Table

		THICKNESS (mm)	HEAT LOST (W)	EFFECTIVENESS	EFFICIENCY
RECTANGULAR	Al 204	3	132.369	56.56	15.3
		2.5	140.64	61.96	11.5
	Al 6061	3	128.64	69.28	11
		2.5	135.09	75.89	8.8
	Mg	3	131.21	65.11	12.4
		2.5	132.27	71.33	11.8
CIRCULAR	Al 204	3	269.9	56.6	23.33
		2.5	269	61.96	26.2
	Al 6061	3	151.04	69.28	26.99
		2.5	151	75.89	26.8
	Mg	3	272.47	65.11	19.3
		2.5	272.47	71.33	19
CURVED	Al 204	3	69.84	56.56	23.33
		2.5	43.32	61.96	10
	Al 6061	3	64.49	69.28	12.7
		2.5	70.48	75.89	12.2
	Mg	3	62.76	65.11	13.9
		2.5	58.15	71.33	12.7

## Conclusion

In this project we have designed a cylinder fin body used in a 100cc Hero Honda Motorcycle and modeled in parametric 3D modeling software Pro/Engineer. Present used material for fin body is Aluminum alloy 204. We are replacing with Aluminum alloy 6061 and magnesium alloy. The shape of the fin is rectangular; we have changed the shape with circular and curve shaped. The default thickness of fin is 3mm; we are reducing it to 2.5mm.

By reducing the thickness and also by changing the shape of the fin to curve shaped, the weight of the fin body reduces thereby increasing the efficiency. The weight of the fin body is reduced when Magnesium alloy is used.

We have done thermal analysis on the fin body by varying materials, geometry and thickness. By observing the analysis results, using circular fin, material Aluminum alloy 6061 and thickness of 2.5mm is better since heat transfer rate is more. But by using circular fins the weight of the fin body increases. So if we consider weight, using curved fins is better than other geometries. So we can conclude that using material Aluminum alloy 6061 is better, reducing thickness to 2.5mm is better and using fin shape circular by analysis and fin shape curved by weight is better. We have also done theoretical calculations to determine the heat lost, effectiveness and efficiency of the fins. By observing the results, using circular fins the heat lost is more, efficiency and effectiveness is also more.

## Future Scope

In this thesis, we concluded that using circular fins is better, but circular fins are mostly used in vertical engines than horizontal engines and also by using that, the weight of the fin body is also increases. By using curved fins, the fin body weight is less, so more experiments are to be done to use curved fins for the fin body in future.

## References

- [1] Thornhill D., Graham A., Cunningham G., Troxier P. and Meyer R., *Experimental Investigation into the Free Air-Cooling of Air-Cooled Cylinders*, SAE Paper 2003-32-0034, (2003)
- [2] Thornhill D., Stewart A. and Cuningham G., *The Queen's University of Belfast Troxler P., Meyer R. and Price B. Harley-Davidson Motor Co. Experimental Investigation into the Temperature and Heat Transfer Distribution around Air-Cooled Cylinders* SAE paper 2006-32-0039/20066539 (2006)
- [3] Thornhill D. and May A., *An Experimental Investigation into the Cooling of Finned Metal Cylinders in a free Air Stream*, SAE Paper 1999-01-3307 (1999)
- [4] Gibson H., *The Air Cooling of Petrol Engines*, *Proceedings of the Institute of Automobile Engineers*, Vol. XIV, 243-275 (1920)
- [5] Biermann E. and Pinkel B., *Heat Transfer from Finned Metal Cylinders in an Air Stream*, NACA Report No. 488 (1935)
- [6] Masao Yoshida, Soichi Ishihara, Yoshio Murakami, Kohei Nakashima and Masago Yamamoto, *Air-Cooling Effects of Fins on Motorcycle Engine*, *JSME International Journal, Series B*, 49(3), (2006)
- [7] Zakhirhusen, Memon K., Sundararajan T., Lakshminarasimhan V., Babu Y.R. and Harne Vinay, *Parametric study of finned heat transfer for Air Cooled Motorcycle Engine*, SAE Paper, 2005-26-361, (2005)
- [8] Zakirhusen, Memon K. and Sundararajan T., *Indian Institute of Technology Madras, V. Lakshminarasimhan, Y.R. Babu and Vinay Harne, TVS Motor Company Limited, Simulation and Experimental Evaluation of Air Cooling for Motorcycle Engine*, 2006-32-0099 / 20066599 (2006)
- [9] Pathak Sunil, *Turbo charging and oil techniques in light motor vehicles*, *Res.J. Recent Sci*, 1(1), 60-65 (2012)
- [10] Dev Nikhil, Attri Rajesh, Mittal Vijay, Kumar Sandeep, Mohit, Satyapal, Kumar pardeep, *Thermodynamic analysis of a combined heat and power system*, *Res.J. Recent Sci*, 1(3), 76-79 (2012)